

INTERNATIONAL JOURNAL OF
INNOVATIONS IN APPLIED SCIENCE
AND ENGINEERING

e-ISSN: 2454-9258; p-ISSN: 2454-809X

Leveraging the Internet of Things (IoT) Tools and
Techniques in Developing Smart Waste
Management System

Naman Verma

Paramount International School, Dwarka, New Delhi

Paper Received: 07th April 2021; **Paper Accepted:** 19th May 2021;

Paper Published: 02nd June 2021

How to cite the article:

Naman Verma, Leveraging the Internet of Things (IoT) Tools and Techniques in Developing Smart Waste Management System, IJIASE, January-December 2021, Vol 7; 143-147

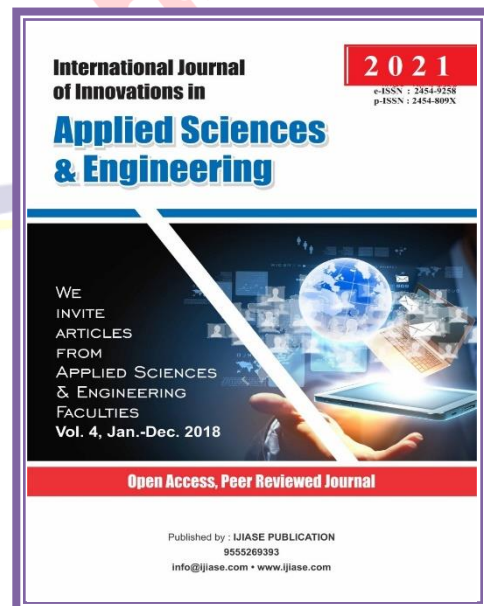

ABSTRACT

Indian urban region creates lots of waste yearly. Our nation faces significant difficulties connected with the management of waste.

An effective method of waste removal and a variety of organized trash is compulsory for an economical and clean India. The usual trash mixture is wasteful since professionals are not informed until the waste receptacle is full, which prompts a flood of waste material. This paper presents smart waste management using IoT-based waste containers for mixture and observing the level of waste inside containers. The framework is applied using two ultrasonic sensors, which Node MCU controls. One ultrasonic sensor distinguishes the degree of waste in the canister and recognizes the individual moving toward the receptacle to dump waste. This framework will send the degree of waste in the canister to concerned specialists. This recognition helps in the programmed opening and shutting of the cover. The Servo motor is associated with the cover, which helps shut and open the top. IoT information is kept and noticed utilizing the Blynk application. The offered framework is solid, savvy and can be executed.

INTRODUCTION

The board and waste removal are a test in this day and age. Unloading trash wastes at open landfill locales is a typical dumping method. The removal technique for unloading on open land destinations harms the climate. Uncontrolled unloading of waste on boundaries of towns and urban communities has made overfull landfills, which are not just difficult to recover as a result of the irregular way of unloading yet have serious natural ramifications. At the point when seen for a bigger scope, an unfortunate recuperation rate has hindered the development of the country as well as the economy of the country. Savvy urban communities cover a populace looking for the best way of life and

satisfying our necessities. Through savvy urban areas, present-day virtual offices utilizing ICT arising advancements like the IoT have been fitted to guarantee the city's supportability. According to the viewpoint of waste administration, different IoT-based arrangements additionally had been proposed as a choice to screen and guarantee the wellbeing of social orders. It will be extremely helpful and can be introduced in the garbage at home.

SYSTEM

IAT-Mega's framework 328 Microcontroller recuperates information from different sensors and sends it through IOT. In the proposed framework, two ultrasonic sensors

and one gas sensor module alongside a dustbin by utilizing Atmega328. The ultrasonic sensor is used to check the trash level in the dustbin so it can clean it

conveniently. Gas sensors will identify gases from the encompassing. What not information saves money on the IOT stage.

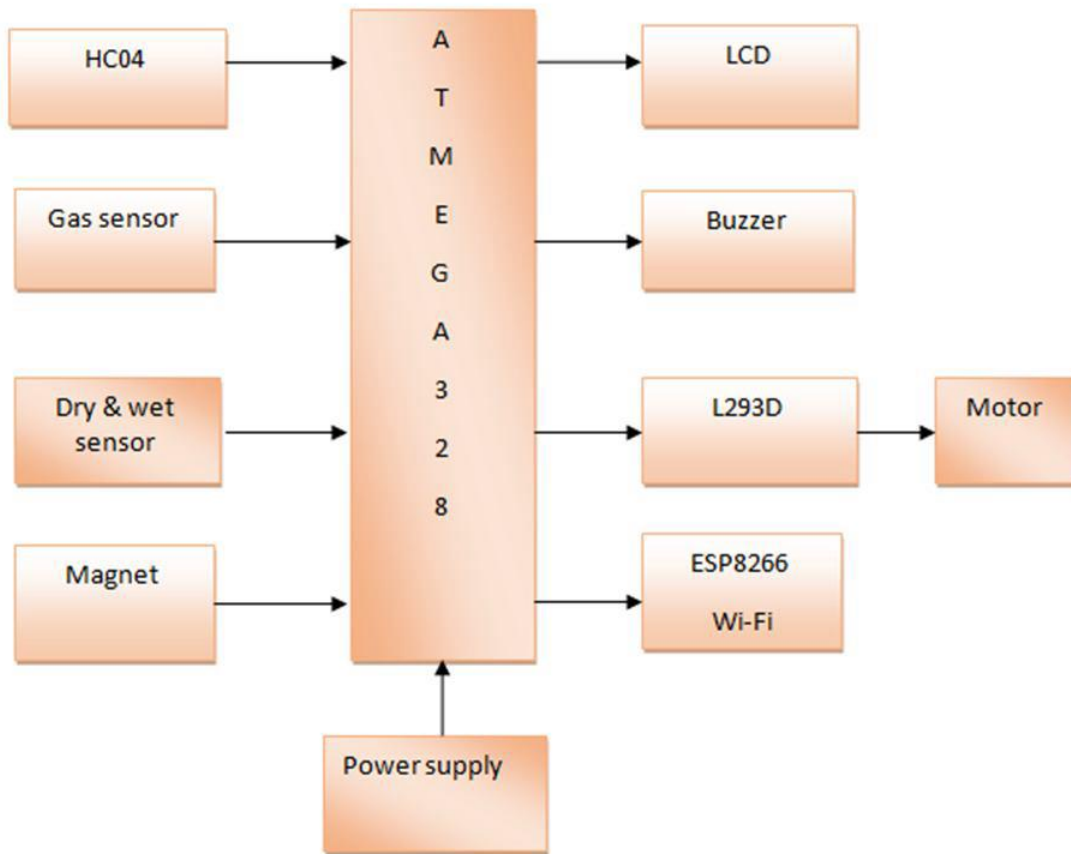

Fig 1: Process Flowchart

The IOT-based squander of the executive's framework is imaginative and will assist with keeping urban areas clean. the framework is made out of parts: Atmega328, ESP8266 Wi-Fi module, Gas sensor, dry and wet sensor.

L293D is a 16-pin Motor Driver IC that has some control over two DC engines at the

same time toward any path. This framework screens trash receptacles, illuminates whether trash gathered is dry or wet, and isolates it. If the dry and wet sensor identifier recognizes the article as dry, n engine pivots and dumps in the dry canister. HC-04 is an ultrasonic sensor that will distinguish the degree of

trash. The gas sensor distinguishes gases from the encompassing. Assuming the degree of trash is distinguished n the ready

framework through a ringer. Also, show results on an LCD.

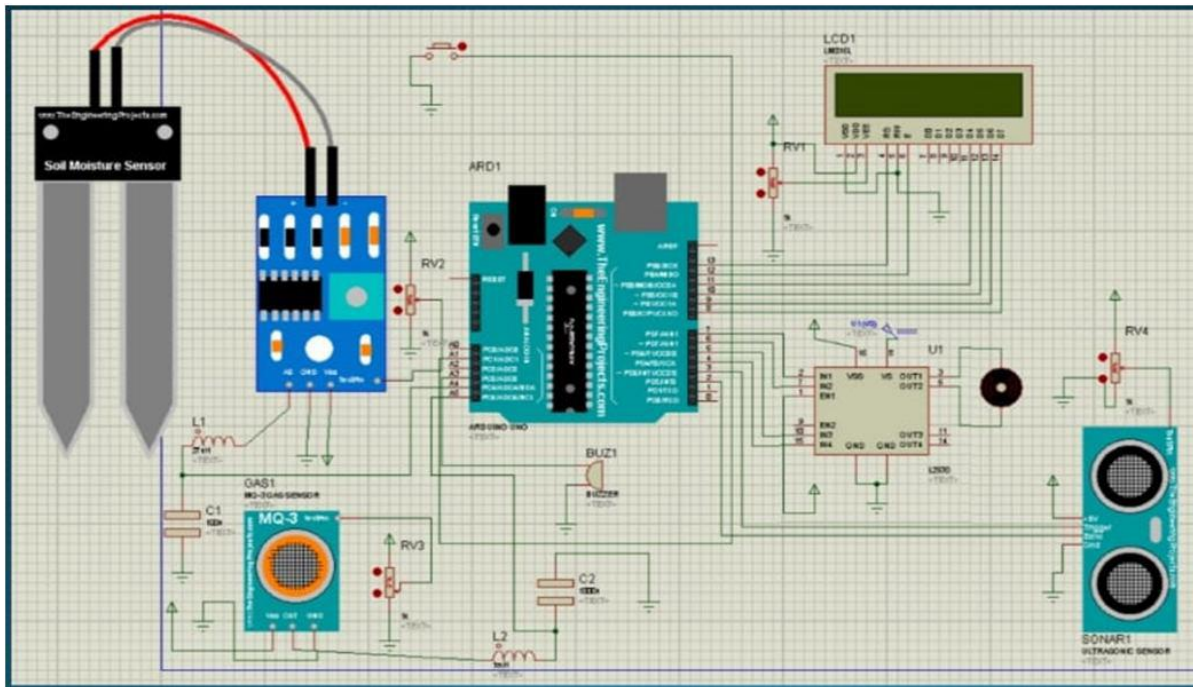

Fig 2: Circuit Diagram

Otherwise, if the item is wet, n engine pivots with a point of dumps in the wet receptacle. In this framework, 12 v of connector power supply is utilized. This The power supply is given to the Arduino board. Two are VCC and distance GND which will be associated with 5V and GND of Arduino, while two pins are Trig and Echo pins which will be associated with computerized pins of Arduino. All information will save money on IOT and be introduced in graphical design.

CONCLUSION

This framework presents a brilliant and practical answer for squandering isolation. The proposed Smart Bin is an effective waste isolation framework that requires no human mediation to isolate dry and wet waste, and all information is saved money on IOT Module. Inappropriate removal furthermore, ill-advised upkeep of homegrown waste creates issues in general wellbeing and natural contamination; accordingly, this framework endeavours to give a pragmatic arrangement towards overseeing waste,

teaming up it with the utilization of IOT, for example, giving free web offices to an exact time once the garbage is unloaded into a container. The offered system will assist with eliminating all difficult issues connected with waste and keep the climate unpolluted.

REFERENCES

- [1] Hassan, M. N. Chong, T. L., & Rahman. M. M. (2005). Solid Waste Management-What's Malaysian Position. Seminar Waste to Energy,
- [2] M. Al-Maaded, N. K. Madi, RamazanKahraman, A. Hodzic, N. G. Ozerkan , “An Overview of Solid Waste Management and Plastic Reusing in Qatar,” Springer Journal of Polymers and Environment, March 2012, Volume 20, Issue 1, pp 186-194
- [3] Islam, M.S. Arebey, M. ;Hannan, M.A. ; Basri, H, “ Indication for solid waste bin observing and collection system” Innovation Management”
- [4] Raghmani Singh, C. Dey, M. “Solid waste management of Thoubal Municipality”, Manipur- a case study of Green Technology and
- [5] Latifah, A., Mohd, A. A., & NurIlyana, M. (2009)” Solid waste management in Malaysia: Performs and challenges”, Waste Management, 29,2902-2906. Waste Segregator”, IJARCET, Volume 5, Issue 2, February 2016.
- [6] Prof B S Malapur, VaniR. Puttanshetti (Pg),”IoT based Waste Management: An Application to SmartCity”, IEEE 2017.
- [7] Sharanya, A, U. Harika, N. Sriya, Sreeja Kochwila.” Auto matic Waste Segregator”, IEEE 2017.
- [8] Davide Anghinolfi, Massimo Paolucci, Michela Robba, “Optimal Planning of Door-to-Door Multiple Materials Separated”
- [9] <https://www.collegedekho.com/colleges/courses-stanley-college-of-engineeringand-technology-for-women>
- [10] <https://smartwaterjournal.springeropen.com/articles/10.1186/s40713-017-0005-y>
- [11] http://ijariie.com/AdminUploadPdf/Implementation_Of_Smart_City_Garbage_Management_ _ijariie5132.pdf